

From \_\_\_\_\_ To \_\_\_\_\_



electric coil service, inc.

531 Water Street • Box 237  
Temple, PA 19560  
Phone: 610.921.3191 • Toll free 1.800.523.8179  
Fax: 610.929.7824 • www.electriccoil.com

C.O. No. \_\_\_\_\_ Date \_\_\_\_\_

HP \_\_\_\_\_ RPM \_\_\_\_\_ PH \_\_\_\_\_ CY \_\_\_\_\_ Volts \_\_\_\_\_ Serial number \_\_\_\_\_

Squirrel cage  Slip Ring  Amps \_\_\_\_\_ Model \_\_\_\_\_ Manufacturer's name \_\_\_\_\_ Frame \_\_\_\_\_  
(Check one)

Duty - Continuous  Intermittent  Hours - temperature rise \_\_\_\_\_ °C Open  TEFC  Totally enclosed  Splash proof

PLEASE ENTER OUR ORDER FOR THE FOLLOWING COILS:

THIS INFORMATION TO BE SUPPLIED BY CUSTOMER

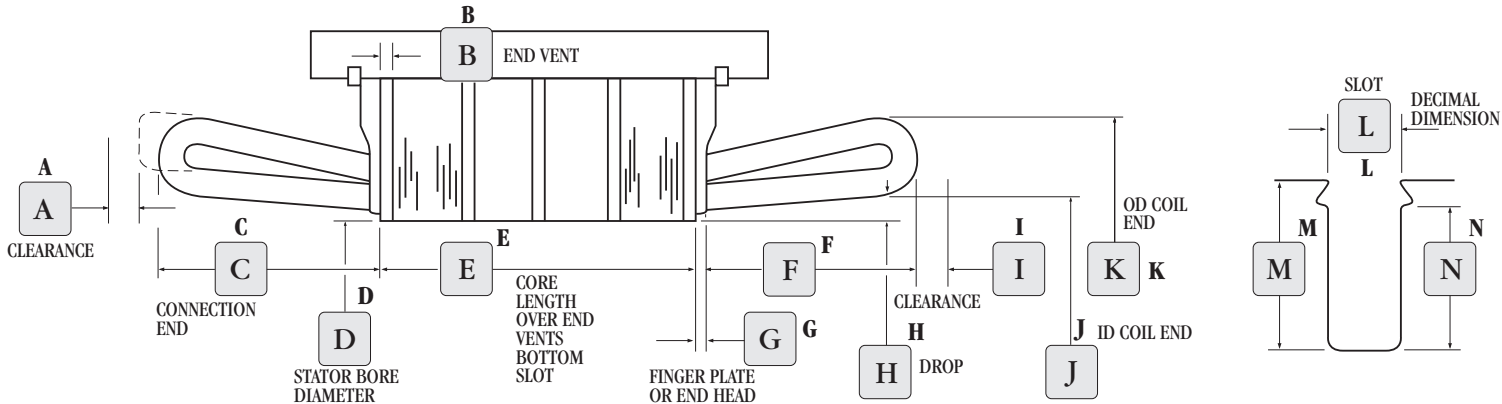

ORIGINAL WINDING DATA

No. of slots \_\_\_\_\_ O Conductor size \_\_\_\_\_ R

Pitch of coil 1 - \_\_\_\_\_ P No. of wires in multiple \_\_\_\_\_ R

Stator connection  No. circuits Y \_\_\_\_\_ Q Turns per coil \_\_\_\_\_ S

Class of insulation: original \_\_\_\_\_  No. circuits \_\_\_\_\_ Q Coil conductor arrangement  Wound flat  or on edge

Conductor size \_\_\_\_\_ No. of wires in multiple \_\_\_\_\_

Process - Tin: Yes  No  Weight/set \_\_\_\_\_

Phase \_\_\_\_\_

Coil leads \_\_\_\_\_ Coil conductor arrangement  Wide \_\_\_\_\_  Deep \_\_\_\_\_

Series \_\_\_\_\_

FURNISH IN LIEU OF SAMPLE COIL

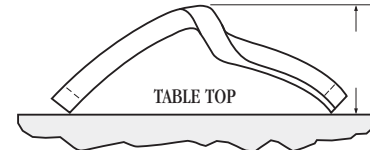
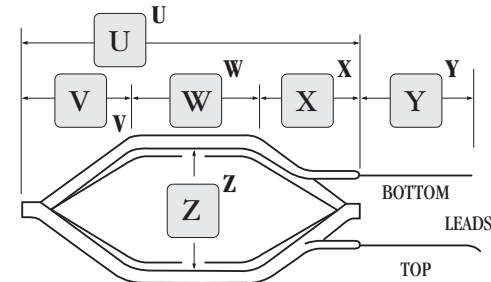

\*CIRCLE COIL TYPE

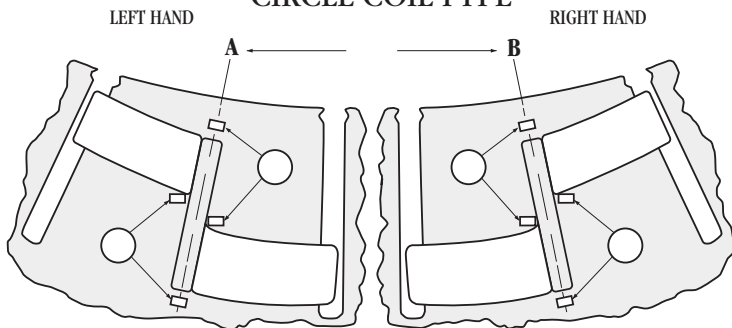

\* CHECK LEAD CONNECTION

VPI — STANDARD — SEALED — HERMETIC

A	_____	H	_____	U	_____
B	_____	I	_____	V	_____
C	_____	J	_____	W	_____
D	_____	K	_____	X	_____
E	_____	L	_____	Y	_____
F	_____	M	_____	Z	_____
G	_____	N	_____		